

THIS DRAWING IS UNPUBLISHED. RELEASED FOR PUBLICATION JUN ,2006.  
 © COPYRIGHT 2006 BY TYCO ELECTRONICS CORPORATION. ALL RIGHTS RESERVED.

LOC	DIST	REVISIONS					
E	B	P	LTR	DESCRIPTION	DATE	DWN	APVD
		B		ECR-06-013423	22JUN06	JMS	FWK

NOTES:

- 1 PACK IN ACCORDANCE WITH AMP SPEC 107-3275
- 2 100 TRAY PACK IN ACCORDANCE WITH AMP SPEC 107-3275
- 3 Au PLATING
- 4 Ni PLATING
- 5 THIS ITEM MUST BE WHITE
- 6 HAND TOOL : 9-1478240-0
- 7 DIE SET : 9-1478242-0
- 8 ELECTRICAL CHARACTERISTICS  
 FREQUENCY RANGE: DC - 4 GHz  
 NOMINAL IMPEDANCE: 50 Ohm  
 INSULATION RESISTANCE: 5000 MOhm  
 WORKING VOLTAGE: 500 Volts RMS at Sea Level  
 DIELECTRIC WITHSTAND VOLTAGE: 1500 Volts RMS Max  
 CONTACT RESISTANCE:  
 CENTRE CONTACT: 1.50 mOhm Max  
 OUTER CONTACT: 0.20 mOhm Max  
 VSWR @ 4GHz: 1.30:1 Max  
 INSERTION LOSS dB @ x 3 GHz: 0.20 Max
- 9 MECHANICAL CHARACTERISTICS  
 COUPLING NUT RETENTION FORCE: N/A  
 CABLE RETENTION FORCE: 170N Min  
 MOUNT NUT RECOMMENDED TORQUE: 4N  
 DURABILITY: 500 Cycles Min
- 10 ENVIRONMENTAL CHARACTERISTICS  
 OPERATING TEMPERATURE: -65 to +165 DegC
- 11 FOR TECHNICAL DATA REFER TO YOUR LOCAL TYCO ELECTRONICS SALES OFFICE
- 12 ALL DIMENSIONS ARE NOMINAL FOR REFERENCE ONLY UNLESS OTHERWISE STATED

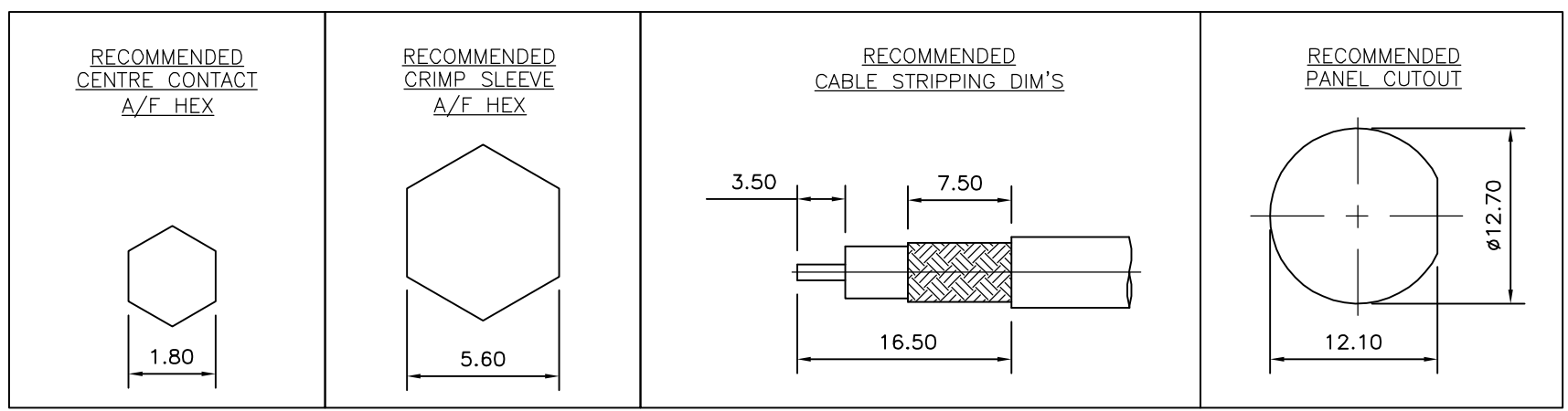
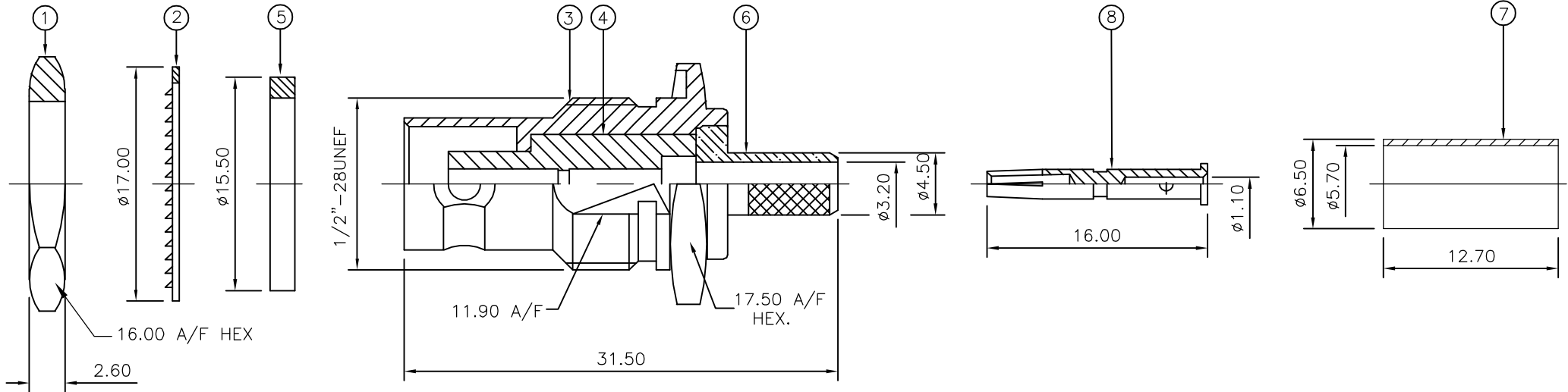

QTY	QTY PER ASSY	MATERIAL	DESCRIPTION	ITEM
1	1	BRASS	CONTACT	8
1	1	BRASS	FERRULE	7
1	1	BRASS	CHASSIS	6
1	1	BRASS	BODY	5
1	1	PTFE	INSULATION	4
1	1	SILICON RUBBER	GASKET	3
1	1	STEEL	LOCKWASHER	2
1	1	BRASS	HEX NUT	1
6--0	1--0	MATERIAL	DESCRIPTION	ITEM

THIS DRAWING IS A CONTROLLED DOCUMENT.		DWN J.SANDWELL 22JUN06	Tyco Electronics Corporation Bideford EX39 4HE	
DIMENSIONS: mm		CHK S.PARLOW 22JUN06		
TOLERANCES UNLESS OTHERWISE SPECIFIED:		APVD F.WHEELER-KING 22JUN06	NAME BNC BULKHEAD JACK REAR MOUNT CRIMP 50 OHM RG55B/U, 142B/U, 223/U, 400/U, URM301, KX23	
0 PLC ± - 1 PLC ± - 2 PLC ± - 3 PLC ± - 4 PLC ± - ANGLES ± - FINISH -		PRODUCT SPEC -	RESTRICTED TO -	
MATERIAL SEE TABLE		APPLICATION SPEC 411-3247	SIZE A3	CAGE CODE 00779
		WEIGHT -	DRAWING NO C-1478092	
		CUSTOMER DRAWING	SCALE NTS	SHEET 1 OF 1